

J&P-Angular doble dentado con laterales (F_{máx} = 15,0 kN)

Referencia-No. 313.002



Sistema de retención de paneles prefabricados de hormigón y retención a estructura.
Unión regulable.

-Especificar el diámetro de la contraplaca dentada, Ø17 ó Ø21.

- Material:
Acero zincado.

ACCESORIOS:

1.- JORDAHL-Raíles JTA K 40/25, ref: 310.040, en forjado y JTA K 50/30, ref. 310.050, en panel

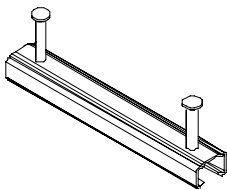

2.- JORDAHL-Tornillo cabeza de gancho JC M 16 y longitud variable en función de la separación entre paneles, ref: 311.040.16

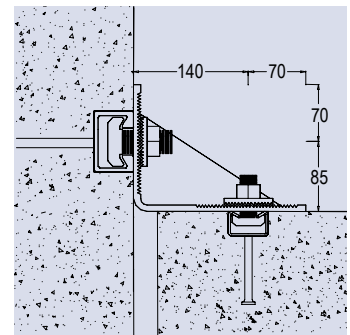
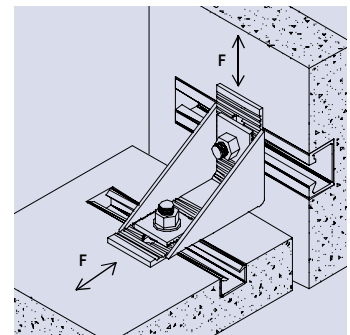
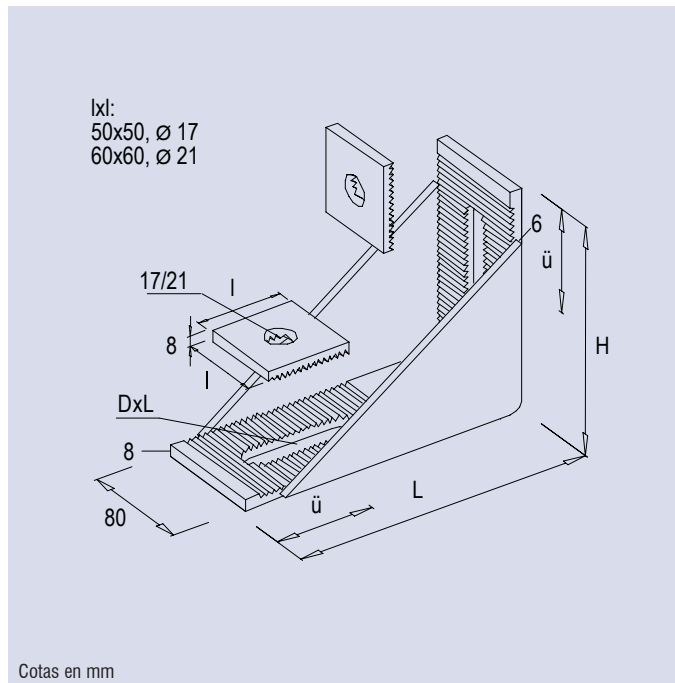
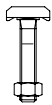

Referencia No.	Carga kN	L mm	Anchura mm	ü mm	H mm	DxL mm	DxL mm
313.002.150.300	15,0	300	80	70	150	17x80	21x80
313.002.155.170		170	80	70	155	17x80	21x80
313.002.155.210		210	80	70	155	17x80	21x80