

# PFEIFER Socket Dowel with cross hole

Item-No. 05.254



**PFEIFER**

Fixing System

Socket Dowels

We recommend Socket Dowels only for fixings, for which a general technical approval is not necessary.

A reinforcement bar has to be inserted through the cross hole thus a safe transmission of the static forces into the concrete is guaranteed.

Load capacity specified (in axial direction) is calculated for concrete compressive strength of 25 N/mm<sup>2</sup>.

Material:

M 6 – M 12  
DIN 2394, St 34-2 NBK

M 16 – M 30  
DIN 1626, St 33/37-2

Stainless steel 1.4571

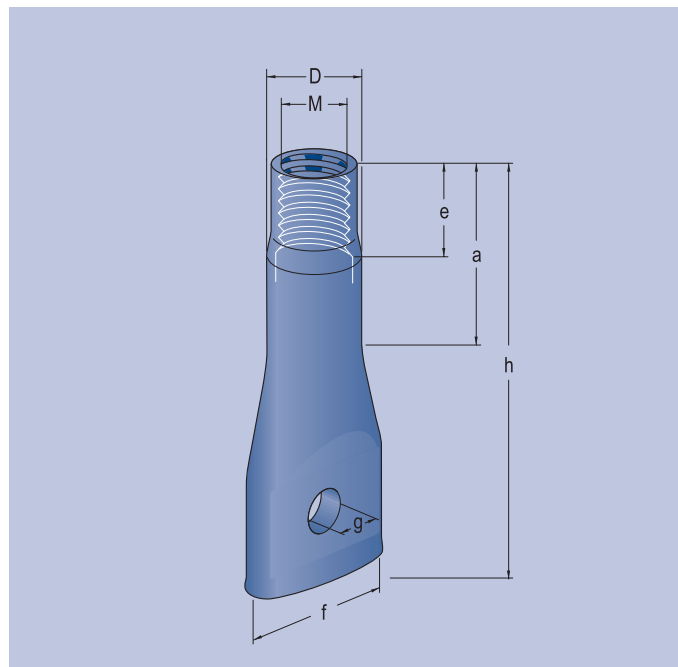

Minimal tolerances from the dimension specifications are possible. They will not influence the load capacity.

Ref. No. black/plain	Ref. No. zinc-plated	Ref. No. stainless steel	Load capacity t	adm. F kN	Size M x h	a	Dimensions mm				Packing- unit pieces	Weight approx. kg/packing unit
						e	f	g	D			
–	05.254.063.040	–	0,15	1,5	6 x 40	25	6	12,5	6,2	8,5	500	3,5
–	05.254.083.040	–	0,20	2,0	8 x 40	25	8	16,0	6,2	10,5	500	4,5
–	05.254.083.050	05.254.084.050	0,25	2,5	8 x 50	25	8	16,0	6,2	10,5	500	5,5
–	05.254.103.050	–	0,35	3,5	10 x 50	24	10	20,0	6,2	13,5	500	10,0
–	–	05.254.104.050	0,35	3,5	10 x 50	24	10	20,0	6,2	13,5	100	2,3
–	05.254.123.060	–	0,50	5,0	12 x 60	25	12	24,5	7,2	17,0	400	16,8
–	–	05.254.124.060	0,50	5,0	12 x 60	25	12	25,0	7,2	17,0	100	3,3
–	05.254.123.070	–	0,60	6,0	12 x 70	30	12	24,5	7,2	17,0	400	19,6
05.254.162.070	05.254.163.070	–	0,70	7,0	16 x 70	25	16	30,5	9,2	21,3	200	18,2
05.254.162.080	05.254.163.080	–	0,80	8,0	16 x 80	25	16	30,0	12,2	21,3	200	20,4
–	–	05.254.164.080	0,80	8,0	16 x 80	25	16	31,0	12,2	21,3	50	5,0
05.254.162.100	05.254.163.100	–	1,00	10,0	16 x 100	32	16	30,5	9,2	21,3	100	13,4
05.254.162.120	05.254.163.120	–	1,20	12,0	16 x 120	32	16	30,5	12,2	21,3	100	15,7
05.254.202.100	05.254.203.100	–	1,25	12,5	20 x 100	40	20	38,5	12,2	26,9	100	16,5
–	–	05.254.204.100	1,25	12,5	20 x 100	40	20	39,0	12,2	26,9	25	3,8
05.254.202.120	05.254.203.120	–	1,40	14,0	20 x 120	40	20	38,5	14,2	26,9	100	21,0
05.254.242.120	05.254.243.120	–	1,80	18,0	24 x 120	50	24	48,0	14,2	33,7	50	16,7
05.254.302.150	05.254.303.150	–	2,75	27,5	30 x 150	70	30	64,0	15,2	42,0	25	13,8

Sample order: 200 PFEIFER Socket Dowel with cross hole, plain, M 16 x 80 mm:  
200 PFEIFER Socket Dowel ref. no. 05.254.162.080

# Instructions for PFEIFER Socket Dowels with cross hole

## 1. Installation

To be able to transfer forces into the concrete a reinforcement bar is put through the cross hole. The largest bar diameter should be chosen that passes through the cross hole. The socket dowel can be nailed to the formwork by PFEIFER Nail Disc or with a hexagonal bolt bolted through a hole in the formwork.

## 2. Straight pull

To avoid premature failure of the Socket Dowel caused by blow-out of the concrete under straight pull, the socket dowel has to be a minimum edge distance. Table 1 and figure 1 show the minimum values for a hardened concrete with a compressive strength of 25 N/mm<sup>2</sup>.

**Table 1 – edge distance for axial pull**

Size mm x mm	adm. F <sub>Z</sub> kN	min a <sub>r</sub> (Z) mm
M 6 x 40	1,5	60
M 8 x 40	2,0	60
M 8 x 50	2,5	75
M 10 x 50	3,5	75
M 12 x 60	5,0	90
M 12 x 70	6,0	105
M 16 x 70	7,0	105
M 16 x 80	8,0	120
M 16 x 100	10,0	150
M 16 x 120	12,0	180
M 20 x 100	12,5	150
M 20 x 120	14,0	180
M 24 x 120	18,0	180
M 30 x 150	27,5	225

## 3. Transversal pull

If the Socket Dowel is exposed to shear forces (vertically to the longitudinal axis of the Socket Dowel) in the direction of the free edge, there is danger of concrete blow-out. To make sure the forces are transferred properly to the concrete certain minimum edge distances (a<sub>r</sub>) and minimum thickness of panel (d) should be kept. Therefore see table 2 and figure 2. Greater concrete cover may result in thicker precast concrete panels.

**Table 2 – edge distance, thickness of the panels under shear forces**

Size mm x mm	adm. F <sub>Q</sub> kN	min a <sub>r</sub> (Q) mm	min d mm
M 6 x 40	1,5	80	65
M 8 x 40	2,0	80	65
M 8 x 50	2,5	100	75
M 10 x 50	3,5	100	75
M 12 x 60	5,0	120	85
M 12 x 70	6,0	140	95
M 16 x 70	7,0	140	95
M 16 x 80	8,0	160	105
M 16 x 100	10,0	200	125
M 16 x 120	12,0	240	145
M 20 x 100	12,5	200	125
M 20 x 120	14,0	240	145
M 24 x 120	18,0	240	145
M 30 x 150	27,5	300	175

**Figure 1**

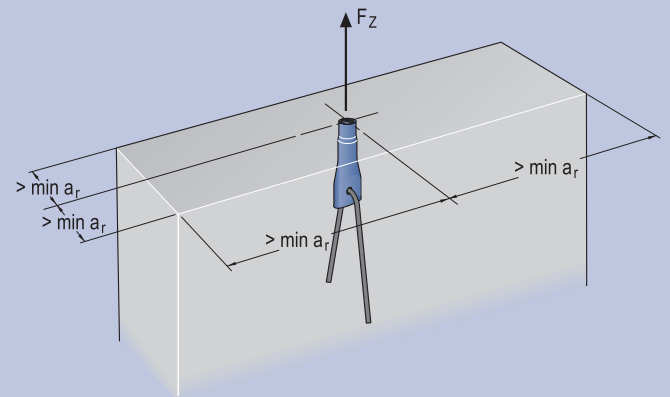

**Figure 2**

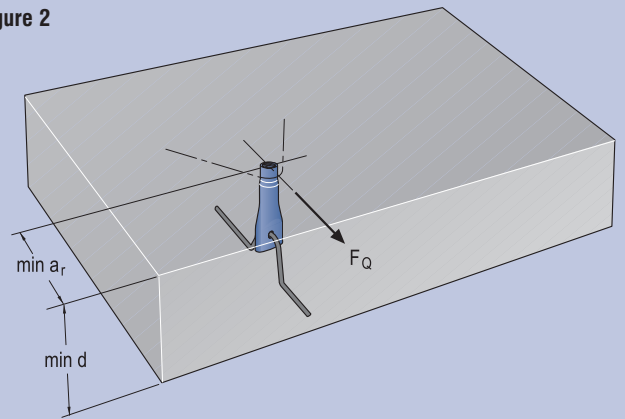

## 4. Parallel shear force (interaction)

We speak of shear force if there is straight pull and angular shear simultaneously working on the Socket Dowel. Their force components should be calculated according to the following formula:

$$\sqrt{F_z^2 + F_Q^2} \leq \text{adm } F$$

This means for an angle of inclination of 90° the same admissible force is valid.

## 5. Example of application

In figure 3 we show a typical example of an application of PFEIFER Socket Dowels: bench consoles fixed with Socket Dowels to a foundation.

**Figure 3**

